

Cam Action Indexing Plungers

Threaded Body Zinc Die Casting

SPECIFICATION

Types

- Type **A**: without lock nut
- Type **AK**: with lock nut

Guide

Zinc die casting
Zinc plated, blue passivated

Plunger Pin

Steel
zinc plated, blue passivated

Lever

Plastic (Polyamide PA)
- black, matt
- not removable



INFORMATION

Cam action indexing plungers GN 612.8 are used in cases where the locking pin must not protrude all the time. By rotating the lock through 180° the locking pin withdraws itself. The groove allows safe positioning.

These cam action indexing plungers made of die-cast zinc are very reasonably priced design versions.

- Range of cam action indexing plungers (see page 816)

TECHNICAL INFORMATION

- Plastic characteristics (see page A2)
- Load rating information (see page A42)

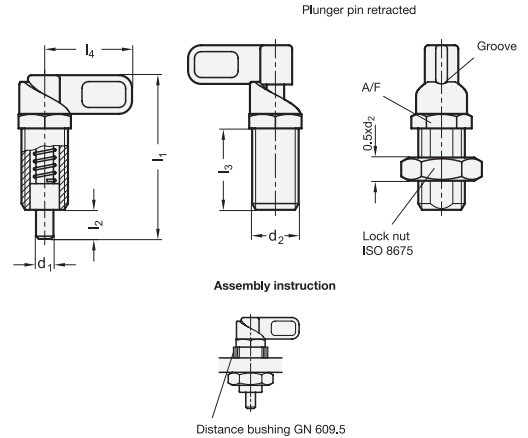

GN 612.8

Description	d1 Pin-0.05 Bore +0.1/+0.05	d2	l1	l2	l3	l4	A/F	Max. tightening torque in Nm	Spring load in N ≈ initial	Spring load in N ≈ end	⚖
GN 612.8-4-M12x1,5-A	4	M 12 x 1.5	48	8	25	25	13	12	8	22	49
GN 612.8-5-M12x1,5-A	5	M 12 x 1.5	48	8	25	25	13	12	8	22	51
GN 612.8-6-M12x1,5-A	6	M 12 x 1.5	48	8	25	25	13	12	8	22	23
GN 612.8-6-M16x1,5-A	6	M 16 x 1.5	56.5	10	28	30	18	20	11	30	45
GN 612.8-8-M16x1,5-A	8	M 16 x 1.5	56.5	10	28	30	18	20	11	30	47
GN 612.8-8-M20x1,5-A	8	M 20 x 1.5	69.5	12	36	37	22	30	20	56	94
GN 612.8-10-M16x1,5-A	10	M 16 x 1.5	56.5	10	28	30	18	20	11	30	49
GN 612.8-10-M20x1,5-A	10	M 20 x 1.5	69.5	12	36	37	22	30	20	56	92
GN 612.8-12-M20x1,5-A	12	M 20 x 1.5	69.5	12	36	37	22	30	20	56	100
GN 612.8-4-M12x1,5-AK	4	M 12 x 1.5	48	8	25	25	13	12	8	22	29
GN 612.8-5-M12x1,5-AK	5	M 12 x 1.5	48	8	25	25	13	12	8	22	60
GN 612.8-6-M12x1,5-AK	6	M 12 x 1.5	48	8	25	25	13	12	8	22	31
GN 612.8-6-M16x1,5-AK	6	M 16 x 1.5	56.5	10	28	30	18	20	11	30	60
GN 612.8-8-M16x1,5-AK	8	M 16 x 1.5	56.5	10	28	30	18	20	11	30	59
GN 612.8-8-M20x1,5-AK	8	M 20 x 1.5	69.5	12	36	37	22	30	20	56	130
GN 612.8-10-M16x1,5-AK	10	M 16 x 1.5	56.5	10	28	30	18	20	11	30	65
GN 612.8-10-M20x1,5-AK	10	M 20 x 1.5	69.5	12	36	37	22	30	20	56	128
GN 612.8-12-M20x1,5-AK	12	M 20 x 1.5	69.5	12	36	37	22	30	20	56	130